

Refrigerator InstructionManual

Model: VBBM0840EWE/EWEI

Model: VBBM1200EWE/EWEI

SUMMARY

SAFETY INFORMATION	2
SCRAPPING OLD APPLIANCES.....	6
Energy Saving	7
Before first use.....	7
Fridge use	8
Freezer use.....	9
Chiller Zone drawer	9
Storage	10
Control panel.....	11
Instructions for Ice Maker	13
LED light replacement instructions.....	14
Care and Cleaning;Defrosting	15
Troubleshooting	16
Installation preparation	17
Ventilation	18
Installation Instruction	23
Reversing the appliance doors.....	26

Thank you for purchasing this product.

Before using your refrigerator, please carefully read this instruction manual in order to maximize its performance. Store all documentation for subsequent use or for other owners. This product is intended solely for household use or similar applications such as:

The kitchen area for personnel in shops, offices and other working environments On farms, by clients of hotels, motels and other environments of a residential type At bed and breakfasts(B&B)

For catering services and similar applications not for retail sale.

This appliance must be used only for purposes of storage of food, any other use is considered dangerous and the manufacturer will not be responsible for any omissions. Also, it is recommended that you take note of the warranty conditions.

SAFETY INFORMATION



This is the Safety Alert Symbol. This symbol alerts you to potential hazards that can kill or injure you and others. All safety messages will follow the Safety Alert Symbol and either the words "DANGER", "WARNING" or "CAUTION".



Danger means that failure to heed this safety statement may result in severe personal injury or death.



Warning means that failure to heed this safety statement may result in extensive product damage, serious personal injury, or death.



Caution means that failure to heed this safety statement may result in minor or moderate personal injury, or property or equipment damage.

All safety messages will alert you to what the potential hazard is, tell you how to reduce the chance of injury, and let you know what can happen if the instructions are not followed.

If the supply cord is damaged, it must be replaced by the manufacturer, its service agent or similarly qualified persons in order to avoid a hazard.

This appliance is not intended for use by persons (including children) with reduced physical, sensory or mental capabilities, or lack of experience and knowledge, unless they have been given supervision or instruction concerning use of the appliance by a person responsible for their safety.

Children should be supervised to ensure that they do not play with the appliance.

This appliance can be used by children aged from 8 years and above and persons with reduced physical sensory or mental capabilities or lack of experience and knowledge if they have been given supervision or instruction concerning use of the appliance in a safe way and understand the hazards involved. Children shall not play with the appliance. Cleaning and user maintenance shall not be made by children without supervision.(EU)

Keep the appliance and its cord out of reach of children less than 8 years.(EU).

Do not store explosive substances such as aerosol cans with a flammable propellant in this appliance.

The max. loading of shelve is 22 lbs(10kg).

The appliance shall be used at an ambient temperature listed according to it's climate class:

89 °F (32°C) ± 35 °F (2°C) on appliances of climatic class 0,1,2,3,4,6 or 8;

109 °F (43°C) ± 35 °F (2°C) Con appliances of climatic class 5 or 7.

The appliance use flammable insulation blowing gas C5H10, disposal of the appliance shall in accordance with the regulations of local authorities.

The appliance provided with double-capped fluorescent lamps, the lamp has to be replaced by identical lamps only.

The key for appliance electric box should be safe kept by qualified persons in order to avoid a hazard

Based on business order(s) to EU market, give true EU authorized representative information on the label with full business name and full EU address in the marking plate.

If the appliance use flammable refrigerant, such as R600a, R290:



Warning; Risk of fire / flammable materials

WARNING: Keep ventilation openings, in the appliance enclosure or in the built-in structure, clear of obstruction.

WARNING: Do not use mechanical devices or other means to accelerate the defrosting process, other than those recommended by the manufacturer.

WARNING: Do not damage the refrigerant circuit.

WARNING: Do not use electrical appliances inside the food storage compartments of the appliance, unless they are of the type recommended by the manufacturer.

WARNING: When positioning the appliance, ensure the supply cord is not trapped or damaged.

WARNING: Do not locate multiple portable socket-outlets or portable power supplies at the rear of the appliance.

WARNING: Do not store explosive substances such as aerosol cans with a flammable propellant in this appliance.

WARNING: To avoid a hazard due to instability of the appliance, it must be fixed in accordance with the instructions

Handling, moving, and use of the refrigerator or freezer to avoid either damaging the refrigerant tubing, or increasing the risk of a leak

L'opération, le mouvement et l'utilisation du réfrigérant ou le congélateur doivent éviter les dommages du tuyau réfrigérant ou le risque de la fuite.

Cautions – Risk of Fire or Explosion due to Flammable Refrigerant Used. Follow Handling Instructions Carefully in Compliance with U.S. Government Regulations

Component parts shall be replaced with like components and that servicing shall be done by factory authorized service personnel, so as to minimize the risk of possible ignition due to incorrect parts or improper service.

Les pièces de rechange doivent être remplacées par les composants relatifs et les opérations doivent être faites par les professionnels afin de minimiser le risque d'allumage à cause des parts incorrects ou des opérations impropres.

CAUTION – Risk Of Fire Or Explosion Due To Puncture Of Refrigerant Tubing; Follow Handling Instructions Carefully. Flammable Refrigerant Used

DANGER: Risk of child entrapment. Before you throw away your old refrigerator or freezer: Take off the doors. Leave the shelves in place so that children may not easily climb inside.

DANGER: If the LED lamp is damaged, it must be replaced by the manufacturer, its service agent or similarly qualified persons in order to avoid a hazard.

DANGER-Risk Of Fire or Explosion. Flammable Refrigerant Used. Do Not Use Mechanical Devices To Defrost Refrigerator. Do Not Puncture Refrigerant Tubing.

Danger-rique de feu ou explosion. Les articles inflammables réfrigérants utilisés. Ne pas utiliser les appareils mécaniques pour décongeler le réfrigérateur.

DANGER-Risk Of Fire Or Explosion. Flammable Refrigerant Used. To Be Repaired Only By Trained Service Personnel. Do Not Puncture Refrigerant Tubing.

Danger-rique de feu ou explosion. Les articles inflammables réfrigérants utilisés. Il faut être réparé par les professionnels seuls. Ne pas crever le tuyau réfrigérant.

CAUTION-Risk Of Fire Or Explosion. Flammable Refrigerant Used. Consult Repair Manual/Owner's Guide Before Attempting To Service This Product. All Safety Precautions Must be Followed.

Attention-rique de feu ou explosion. Les articles inflammables réfrigérants utilisés. Consultez la spécification de réparation/le guide avant d'essayer de utiliser ce produit. Toutes les précautions en sécurité doivent être respectées.

CAUTION-Risk Of Fire Or Explosion. Dispose Of Property In Accordance With Federal Or Local Regulations. Flammable Refrigerant Used

Attention-rique de feu ou explosion. Détruire la propriété selon les réglementations fédérales ou locales. Les articles inflammables réfrigérants utilisés.

CAUTION-Risk Of Fire Or Explosion Due To Puncture Of Refrigerant Tubing; Follow Handling Instructions Carefully. Flammable Refrigerant Used

Attention-rique de feu ou explosion. Il faut crever le tuyau réfrigérant selon l'instruction d'opérations. Les articles inflammables réfrigérants utilisés.

This appliance is intended to be used in household and similar applications such as

- staff kitchen areas in shops, offices and other working environments;
- farm houses and by clients in hotels, motels and other residential type environments;
- bed and breakfast type environments;
- catering and similar non-retail applications.

Disposal of Old Appliance

Dispose of your appliance packaging properly. Refrigeration equipment must be properly disposed of in a way which protects the environment. This applies to your old appliance and to your new unit once it has reached the end of its service life. Please according to local regulations regarding disposal of the appliance for its flammable refrigerant and blowing gas.

WARNING: Please ensure that old, worn appliances are rendered unusable before disposal by removing the plug, cutting the power cable, and removing or destroying any snap fastenings or bolts. You will thus prevent children from locking themselves in the appliance during play (risk of suffocation) or endangering their lives in any other way.

The appliance must not be disposed with normal household waste collection.

The coolant circuit, particularly the heat exchange at the back/bottom of the unit, must not be damaged.

The symbol on the product or its packaging indicates that this product is not to be handled as normal household waste but is to be taken to a recycling collection point for electrical and electronic goods. By correctly disposing of this product you are contributing to the protection of the environment. Improper disposal endangers health and the environment. Further information about the recycling of the product may be obtained from your town hall or local waste collection department.

Energy Saving

For better energy saving we suggest :

- Installing the appliance away from heat sources and not exposed to direct sunlight and in a well ventilated room.
- Avoid putting hot food into the refrigerator to avoid increasing the internal temperature and therefore causing continuous functioning of the compressor.
- Do not excessively stuff foods so as to ensure proper air circulation.
- Defrost the appliance in case there is ice to facilitate the transfer of cold.
- In case of absence of electrical energy, it is advisable to keep the refrigerator door closed.
- Open or keep the doors of the appliance open as little as possible
- Avoid adjusting the setting to temperatures too cold.
- Remove dust present on the rear of the appliance

Before first use

You must allow the fridge to settle for at least four hours prior to switching the power on.

It is recommended that you clean the interior of the appliance prior to first use, using a solution of bicarbonate of soda and warm water and then thoroughly drying the interior. The fridge may have an odor to it at first use. This will disappear as the appliance cools.

Please note:

The appliance will start 41 °F (5°C) for fridge and -0.5 °F(-18°C) for freezer and work continuously until it comes down to the correct temperature. If the appliance is switched off, you should allow five minutes before switching it on again to prevent unnecessary damage to the compressor. Never store inflammable or explosive items and strong corrosive acids or alkalis in the appliance. This fridge cools your food by making the inside back of the cavity cold. It is normal for frost to build up on this surface; it then dissipates and drains through a small drain at the bottom, where it evaporates harmlessly. The presence of frosting at the back is not a malfunction of the fridge.

Fridge use

- Never put liquids in the refrigerator uncovered.
- Never put hot foods in the refrigerator. Warm food should be allowed to cool to room temperature before being put into the refrigerator.
- Nothing should rest against the rear wall of the refrigerator, as this will cause frost and possible condensation problems which will be difficult to remove.
- Make sure food is clean and any extra water is wiped away before putting into the fridge.
- Wrap or cover food before putting into the fridge. This will help prevent the loss of moisture, keep food fresh and avoid unpleasant odors.
- Sort foods prior to storing. Any foods to be used soon should be stored at the front of the shelf to prevent deterioration caused by the door being open for prolonged periods.
- Do not overfill the fridge. There should be sufficient space between the foods to allow the cool air to circulate.
- Thawing frozen foods in the fridge compartment will help to keep the temperature low and save energy.
- Never store raw meats on shelves above cooked meats or other produce. This will help to prevent juices from raw meat contaminating other foodstuffs.

Freezer use

- The freezer compartments are designed to store only frozen food.
- Never put hot or warm foods in the freezer, allow them to cool fully before putting them into the freezer.
- Follow the instructions on the food packaging for storage of frozen food. If no information is provided, foods should not be stored for more than three months after the purchase date.
- Store food in small packages (ideally less than 2.2 lbs (1kg)).This reduces the freezing time and improves the quality of the food after thawing.
- Wrap food before putting into the freezer. To stop the wrapping sticking together, ensure it is dry.
- Label the food before freezing with information including type of food and dates of storage and expiry.
- Once food is thawed, it must not be refrozen. Only defrost as much food as is required to prevent wastage.
- Bottled or canned drinks should not be stored in the freezer compartments as they could explode.
- The maximum amount of fresh food that can be frozen within a 24 hour period is 5.8 lbs (2.6kg).
- Do not attempt to freeze more than the maximum amount.

Chiller Zone drawer

- The temperature inside the My Zone drawer can be regulated from 37°F(3°C) to 26°F (-3°C). This is the ideal drawer to store meat and fish.

Storage

The fridge section is for short term food storage. Although low temperatures can be maintained, extended periods of food storage is not recommended.

As the cold air circulates within the fridge, the temperature can vary between the different sections. As such, foods should be stored in different sections according to type.

1. Butter, cheeses etc.
2. Food in jars and bottles
3. Drinks, e.g. milk
4. Cooked food
5. Yogurts, preserves etc.
6. 75cl bottles or ready meals etc.
7. Fruit and vegetables
8. Fresh meat and fish/fruit and vegetables
9. Storage of ice cubes

The fridge shelves can be moved according to the storage requirements within the fridge section. To move the shelf, lift up the rear section and then pull it outwards.

To replace, slide the shelf back into the slot, and then lower the rear section.

The most energy-saving configuration requires drawers, food box and shelves to be positioned in the product, please refer to the above pictures.

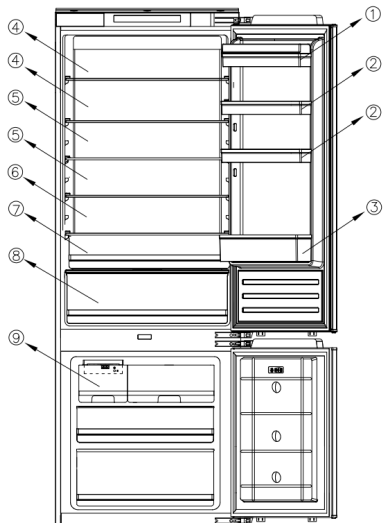
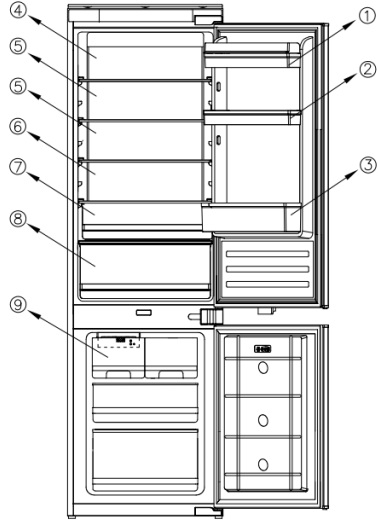



Control panel





1. First time of switching on the appliance, this appliance always works at settings: 41 °F (5°C) for fridge, 32°F (0°C) for My Zone 0.5 °F(-18°C). If you want to adjust the temperature or functions manually, press and hold the button to conduct the operations. Temperature ranges of adapt zone from 37°F(3°C) to 26°F (-3°C).

2. Fridge temperature adjustment –press button  on left part of control panel to achieve different temperatures from 35°F (2°C) to 46°F (8°C).

3. Freezer temperature adjustment –press button  on right part of control panel to achieve different temperatures from 5°F(-15)°C to-15°F(-25°C).

4. Chiller Zone drawer adjustment function: this button  controls temperature. By pressing on this button, the digit will go from 37°F(3°C) to 26°F (-3°C). This function can be on/off by continuously pressing for three seconds (shows OFF).

5. Fast cooling function –Press button , light of button illuminates and fast cooling function is turned on, fridge starts to work automatically at temperature setting 35°F(2°C) and quits after 24 hours, light of symbol eliminates.

6. Holiday function–Press button , light of button illuminates, holiday function is turned on and whole appliance starts to work automatically at settings: fridge at 62°F(17°C) and freezer at -0.5°F(-18°C).

7. Eco function – Press button  on control panel, eco function is turned on and button illuminates, fridge compartment works at setting 41°F (5°C) and freezer compartment works at setting of-0.5°F(-18°C).The adapt zone works at setting of 37°F(3°C).

8. Fast freezing function – Press button , light of button illuminates and freezer start to work at fast freezing function, temperature setting -15°F(-25°C). After 24 hours, fast freezing function quits automatically.



9. Press button for 3 seconds to switch off your appliance and the button illuminates, power is cut

off. Internal lamps eliminate, compressor stops working. Press the button  for 3 seconds to

switch on your appliance, the symbol illuminated and power is connected again.

10. On the no frost models, there is a function: compulsive defrosting. Press the buttons 

+  for 5 seconds to switch on the compulsive defrosting function to clean the freezer

evaporator and digitals of freezer temperature shine. Press the button  +  3 seconds to switch off the compulsive defrosting function, and the digitals of freezer temperature eliminate.

10 Fault display

This appliance has 'fault display & alarm' function. Once the sensors got fault, there are alarms displayed on the temperature displaying, the appliance still cools but professional service engineer should be called and check the appliance.

F2 – Sensor of adapt zone

F3 – Sensor of fridge apartment

F4 – Sensor of freezer compartment

F5 – Sensor of defrosting

2E – Fault of fan/motor in freezer

CE– Communication fault between main panel and display panel.

The above Errors only show on display, no voice

Over temperature alarm in freezer: after freezer temperature arrives at the set temperature, after that, if the temperature rises to $>77^{\circ}\text{F}$ (-1°C), the alarm will start, accompany with flash of freezer temperature digit. Press any button to cancel the voice alarm. The flash will remain until the temperature is $<77^{\circ}\text{F}$ (-1°C).

PS: Main board locates in compressor compartm

POSITION	CONDITIONS
41 °F (5°C) - -0.5 °F(-18°C)	Summer or ambient temperature between 77°F(25°C) - 95°F (35 °C)
41 °F (5°C) - -0.5 °F(-18°C)	Spring or ambient temperature between 59°F(15°C) - 77°F (25 °C)
41 °F (5°C) - -0.5 °F(-18°C)	Winter or ambient temperature between 41°F(5°C) - 59°F (15 °C)
Super freezing function	Quick freeze
Super cooling function	Super cooling

Instructions for Ice Maker (if applicable)

1. Connect the waterpipe connector to water source, and check for any connector leakages after water is supplied.
2. Open the freezer door, pull out the ice box, and turn on the ice maker for ice making; Then, install back the ice box.
3. The ice maker indicator shows yellow and is flashing, indicating that ice-making is in process.
4. The ice maker indicator shows yellow and is not flashing, indicating that the ice box is full and ice making is paused.
5. The ice maker indicator shows red and is flashing, indicating that the ice box is not in position or has been pulled out.
6. The ice maker indicator shows red and is not flashing, indicating that the ice maker is malfunctioning

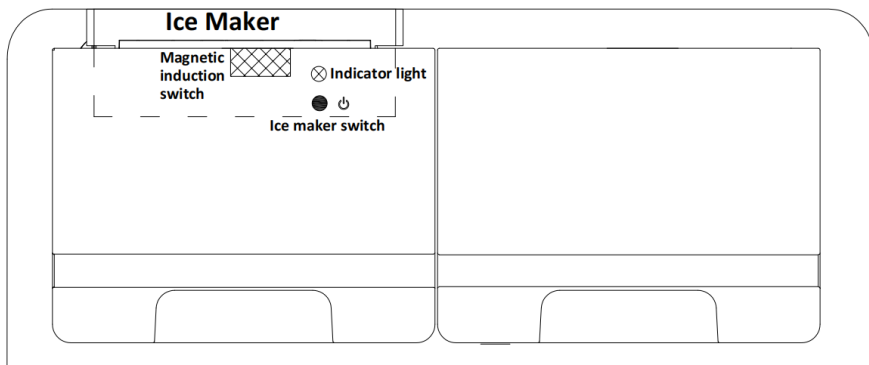

LED light replacement instructions

Note: the LED light is set to be non replaceable by the user and needs to be replaced by professionals.

Lighting parameters: 12V / 10W

1. Unplug the power plug.
2. Remove the aluminum alloy trim strip on the top of the LED surface light source, and then remove the left and right fixing screws.

Steps ① and ② are shown below.

3. Replace the spare LED light board.
4. Replace the aluminum alloy trim strip in turn.

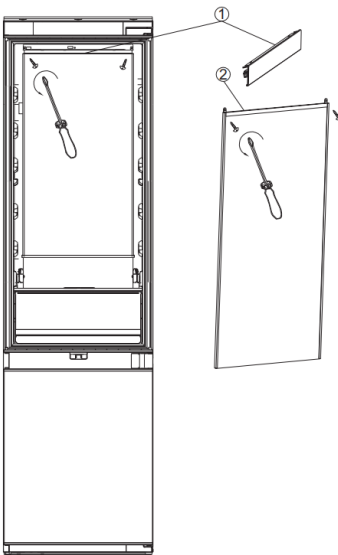

Care and Cleaning

Always disconnect the appliance from the power supply before any cleaning or maintenance.

The fridge and freezer sections should be cleaned using a solution of bicarbonate of soda and lukewarm water. Do not use abrasive products or detergents. After washing, rinse and dry thoroughly.

Clean the shelves and balconies separately by hand with a mild solution of washing up liquid and water. Do not put them in the dishwasher.

If the appliance is not to be used for prolonged periods of time, unplug and clean the appliance. The doors should be left slightly ajar to prevent the formation of mildew and unpleasant odors.

Defrosting

The product has a no frost system which is designed to prevent the heavy build up of ice. Under normal use, there should be no need to regularly defrost the freezer system.

Please note: If you are regularly finding a heavy build up of ice, or pools of water, in the freezer section then it is likely that the door is not sealing properly. This could be due to a defective door seal or an incorrectly fitted, or overly heavy, decor door. For more information see the troubleshooting section about ice.

Troubleshooting

If you have any problems with your appliance, you should check the troubleshooting prior to calling Customer Care.

If the appliance is not working, check:

- That there is power to the appliance.
- The house fuses are intact and the fuse in the plug has not blown.
- The fridge has not been turned off.
- The plug socket is functioning fine. To check this, plug another electrical appliance in to see if the socket is faulty.

If the appliance is working, but not very well, check:

- The appliance is not overloaded.
- The thermostat is set to an appropriate temperature.
- The doors are closing properly.
- The cooling system at the rear of the appliance is clean and free of dust, and not touching the rear wall.
- There is enough ventilation at the side and rear walls.

If the appliance is noisy, check:

- The appliance is level and stable.
- The side and rear walls are clear, and there is nothing resting on the appliance.
- Note: The cooling gas in the refrigerator may make a slight bubbling or gurgling noise, even when the compressor is not running.

If the appliance is beeping, check:

- That the doors are closed. An alarm will sound after 60 seconds of a door being open.

If ice has formed on the back wall of the fridge:

- It is normal for some ice droplets to form on the back wall of the fridge. This does not constitute a fault with the appliance.
- Ensure that no items inside the fridge are in contact with the back wall.

- Check that there is some resistance when opening the door of the appliance. If it opens at the slightest touch it may mean that the door seal needs to be replaced.
- Check the door seal for any kinks, debris or damage. If you notice any, and are unable to resolve the issue yourself, contact Customer Care so that the seal can be replaced.
- This can be due to the decor door(s) not being properly fitted. If you are at all unsure, ask your fitter to check the décor doors.

If excessive ice has formed in the freezer:

- Check that there is some resistance when opening the door of the appliance. If it opens at the slightest touch it may mean that the door seal needs to be replaced.
- Check the door seal for any kinks, debris or damage. If you notice any, and are unable to resolve the issue yourself, contact Customer Care so that the seal can be replaced.
- This can be due to the decor door(s) not being properly fitted. If you are at all unsure, ask your fitter to check the decor doors.

If one or more of the LED units within the appliance is not working:

- Contact Customer Care to arrange a service visit.

Installation preparation

This appliance must never be installed close to heat sources, e.g. heating elements or cookers, nor in damp places.

Seek the help of another individual, or two, when installing this appliance. This appliance may have sharp edges. Wear adequate PPE for the task and environment.

- To ensure the appliance is level, you should use the height adjustable feet at the front of the appliance.
- The cooling system at the rear of the appliance must not touch the rear wall. The greater the gap, the better.
- The appliance must be installed with adequate ventilation. Ensure that there is clearance above the appliance to allow air to escape and that there is space between the rear of the appliance and the wall.

Ventilation

The main consideration when installing any refrigeration unit into a fitted kitchen is ventilation. The heat removed from the cooling compartment needs to be dissipated into the atmosphere. Incorrect ventilation can lead to premature compressor failure, excessive power consumption, total system failure and may invalidate the warranty provided with the appliance. For products intended to be installed into a tall housing unit, the following requirements need to be met:

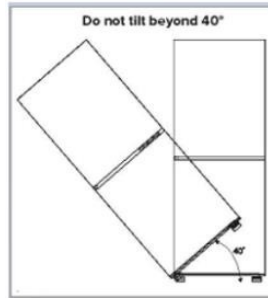

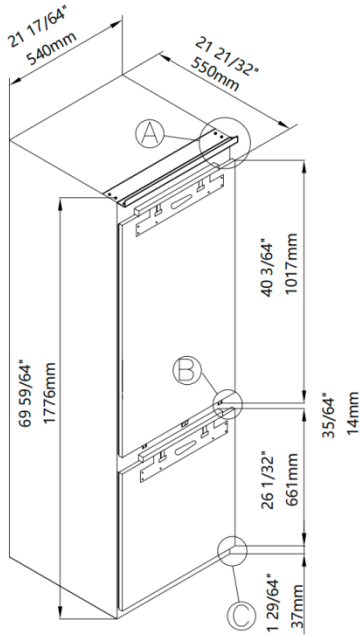
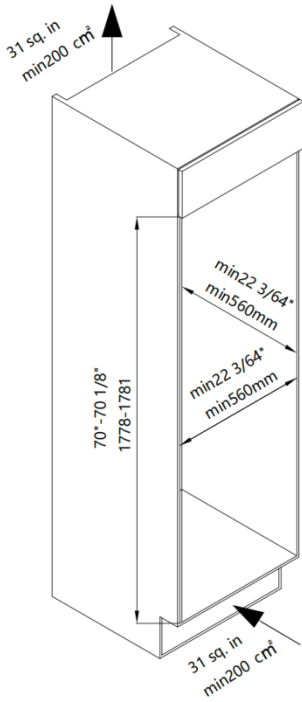

A
6:1

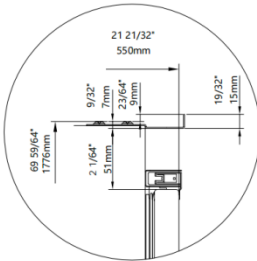

B
6:1

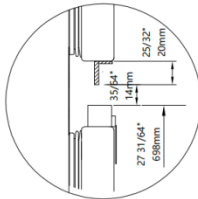

C
6:1

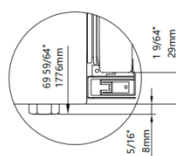

VBBM0840EWE/EWEI

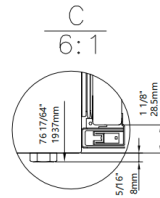
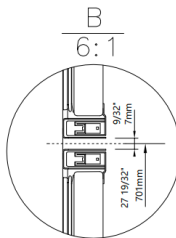
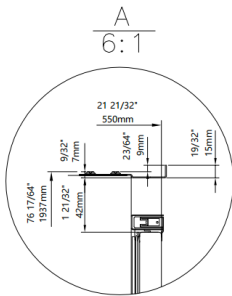
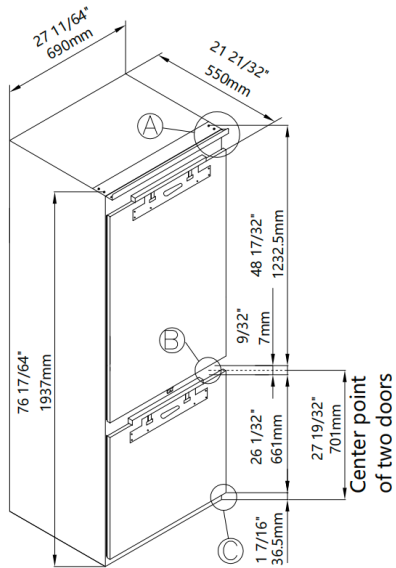
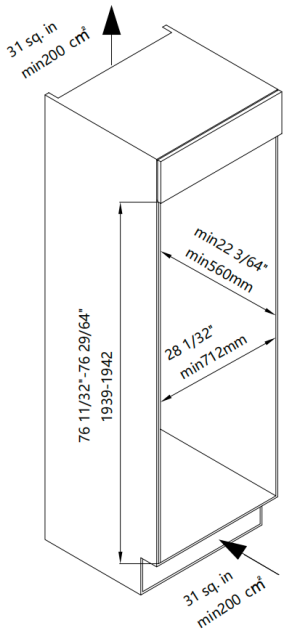

VBBM1200EWE/EWEI

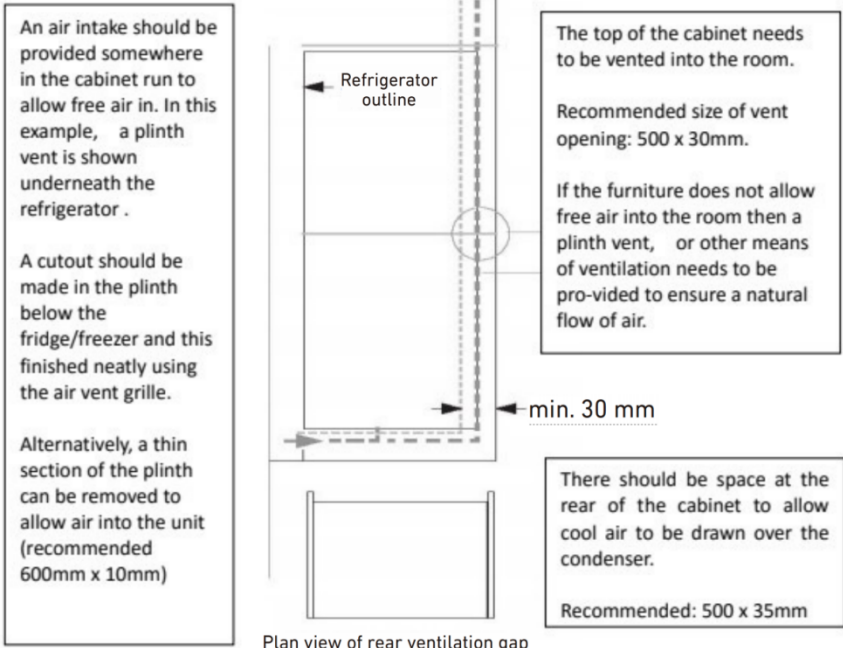

Plan view of rear ventilation gap









The open channel at the rear is clearly shown. For the correct operation of the appliance it is important that the top of the housing unit is not blocked off. A channel depth of 1 37/64" - 1 31/32" (40-50mm) is normal with most units.

A ventilation hole is required in the plinth of the unit; this allows air to be drawn over the compressor & heat exchange.

As a rule, the more air that can get in and out, the better and more efficient the operation of the product.

Installation Instruction

1. Push the appliance into the wooden furniture, the appliance should be better approach furniture left side.

Tools&parts	
	Spacer for hinge A
	Spacer for hinge B
	Hinge cover
	Cross head screw 3.9×12; T20 3.9×16; T20
	Spanner
	Left cover for control panel-spacer
	Right cover for control panel-spacer
	Decoration stripe

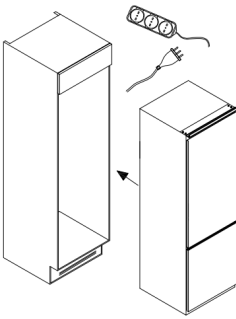

2. Adjust the position of appliance, screw product top and bottom part on the furniture

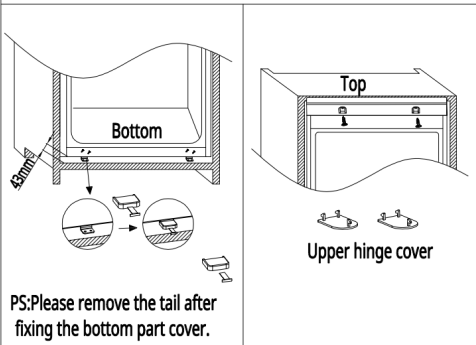

3. Fix the hinge on furniture by screw, attached the decoration stripe on the product left side.

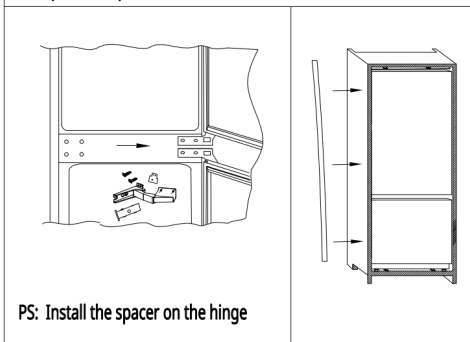

4. Measure the dimension of A and B

Remove the trim cover before measuring

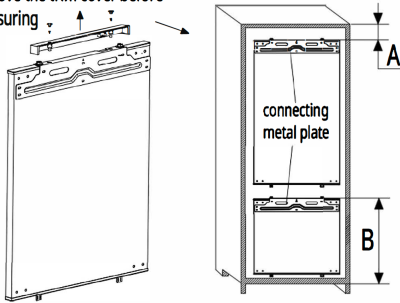

5. Remove the connecting metal plate and install the connecting metal plate on the wooden door

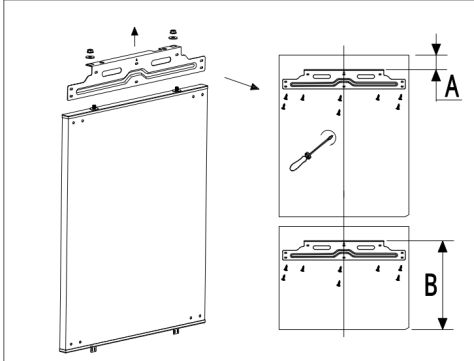

6. Please follow the steps below to connect the wooden door and the refrigerator door

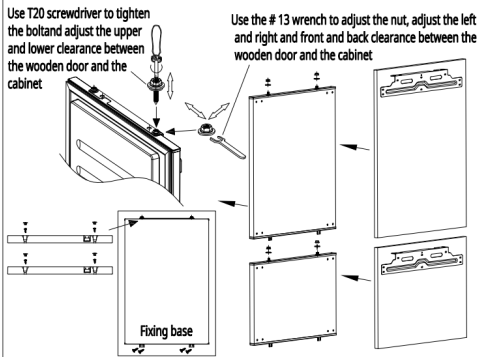

Reversing the appliance doors

We recommend you seek the help of another individual to support the doors whilst performing this operation.

Remove the right upper hinge cover and hinge by screw driver.

1

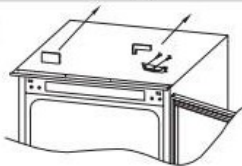

Remove the upper door.

2



Remove the middle hinge and its connecting pin underneath.

3

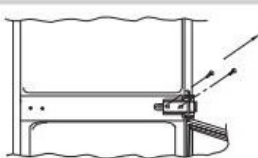

Remove the bottom door.

4



Remove the right bottom hinge and left plastic plugs, and refit them onto the opposite side.

5

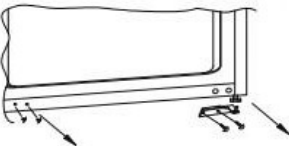

Assembly the right upper hinge to the left bottom and fit the cover.

6

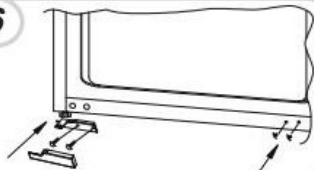

Reassemble the doors and hinges workings from bottom to top, from 1-4.

7

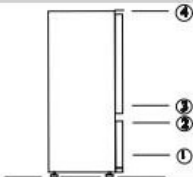

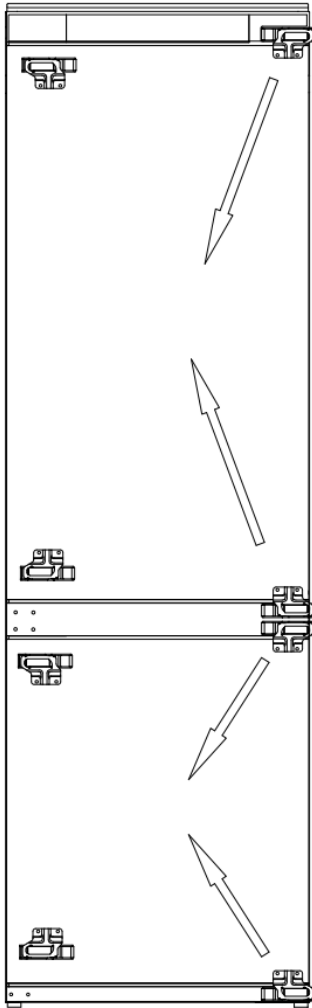

Ensuring the door seals correctly:

It is normal for the seal to be compressed after the door has been reversed. With the door closed, use a hair dryer to expand the seal and fill the gap between the door and the body of the appliance. Take care not to use the hair dryer too close to the appliance, which could damage the seal. A distance of approximately 10cm should be adequate. When completed, allow the seal and door to cool before touching them. Once done, the seal should remain in position.